

TECHNICAL DATA

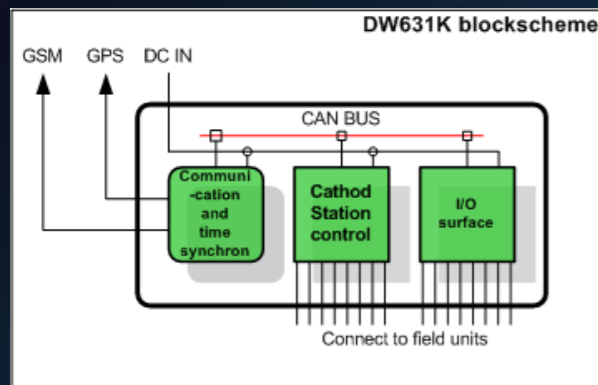

GENERAL CHARACTERISTICS

Power:	24 V DC
Operational Temperature:	-30°C to 60°C
Storage Temperature:	-40°C to 80°C
Humidity:	5-95% non-condensing
Vibration:	2.1 g - 15 - 150 Hz ±2.5 mm deviation
Dimensions (LxWxH):	260×160×90 mm
Protection:	IP66 - IEC529 conform

ANALOG INPUTS

6 inputs for measured cathodic potential
Cathodic station output voltage
Cathodic station output current

Number of analog inputs:	8
Input impedance:	10 ¹⁸ Ohm
Measurement range:	0-100 V
Digital resolution:	24 bit
Measurement precision:	±0.1%
Galvanic separation creepage voltage:	1.5kV
Symmetrical surge protection:	Yes

ANALOG OUTPUTS

Prescribed output voltage control
Prescribed output current limit control

Number of analog outputs:	2
Output impedance:	1 kOhm
Output voltage range:	0-5 V
Digital resolution:	10 bit
Output precision:	±0.1%
Galvanic separation creepage voltage:	1.5 kV
Symmetrical surge protection:	Yes

DIGITAL INPUTS

Sabotage indicator contacts	
Number of digital inputs:	8
Input impedance:	10 kOhm
Voltage range:	0-5 V or 0-24 V (configurable)
Symmetrical surge protection:	Yes
Field communication:	CAN

DIGITAL OUTPUTS

Interruption cycle command issuing	
Number of digital outputs:	1
Output impedance:	100 Ohm
Voltage range:	0-5 V or 0-24 V (configurable)
Galvanic separation creepage voltage:	1.5 kV
Symmetrical surge protection:	Yes

COMMUNICATION PARAMETERS

Internal GSM modem	Sony-Ericsson GM47
Bands (MHz):	900, 1800, 1900
Frequency ranges (MHz):	Tx: 890-915 Rx: 935-960 Tx: 880-890 Rx: 925-935 Tx: 1710-1785 Rx: 1805-1880
Download bandwidth:	Max. 40 kbit/s
Upload bandwidth:	Max. 27 kbit/s
Communication delay:	Max. 1200 ms
Communication standard:	ETSI GSM Phase2
Channel separation:	200 kHz
Number of channels:	173 Carrier*8 (TDMA)
Modulation:	GMSK
Receiver sensitivity at connector:	<-102 dBm
Antenna output at connector:	Class 4 / GSM900 2W (33dBm) Class1 / GSM1800 1W (30 dBm)
Switching between GSM 900 and GSM 1800:	Automatic
IP address distribution:	Dynamic

GPS PARAMETERS

Frequency band:	L1, C/A code
Number of channels:	16
Data refresh cycle time:	0.25 sec
Localization precision:	2.4 m CEP
Cold start time:	45 sec
Warm start time:	8 sec
Time synchronization signal error:	max. 60 ns

DIWICON-K DW 631 K

INTELLIGENT FIELD CATHODIC STATION CONTROL UNIT

The DW 631 K device performs data collection, control, storage, and analysis functions in real time with event oriented communication.

FEATURES

- Station control functions
- Current interruption cycling
- Data collection
- Property protection
- Redundant GPRS event oriented communication
- CAN bus

SPECIAL CHARACTERISTICS

- Expandable CAN bus
- Greater than 99.9% availability
- 8 digital inputs, 1 digital output
- 8 analog inputs, 2 analog outputs
- GPS and GSM antenna
- Time synchronization precision ± 1 ms

INDUSTRIAL DESIGN

- Operational temperature range from -30°C to +60°C
- Installed in IP67/IP68 protection industrial casing (IEC 529 conformity)

APPLICATION

The purpose of the DIWICON-K cathodic protection system is to provide remote controlled cathodic protection for pipelines and to monitor the effectiveness of such protection. To this end, the DW 631 K control unit was developed. The unit, when linked to the cathodic station, provides continuous management and measurement, as well as performing synchronization and transmission of measurement data. The system is capable of measuring the outgoing current and voltage of the cathodic station, controlling voltage and current limits, measuring cathodic potential and cathodic current of three protected objects independent of each, as well as providing a synchronized interruption cycle control signal. Thanks to the GPS time base, the unit ensures precise synchronous operation for several widely separated devices.



CASON

CASON Engineering Plc. Velencei út 37. H-2030 Érd, Hungary

T: +36 (23) 522-100 • F: +36 (23) 522-190

office@cason.hu • www.casonplc.com

FUNCTIONS

- Continuous measurement of cathodic current
- Continuous measurement of cathodic potential
- Continuous measurement of cathodic station output voltage
- Continuous measurement of cathodic station output current
- Control of cathodic station output voltage
- Reception of synchronization signal from the GPS unit
- Reception and storage of configuration messages
- Monitoring of external motion sensor
- Monitoring of internal sabotage sensor
- Monitoring of measurement data fluctuations above limits
- Measurement of environmental temperature
- Switching to automatic interruption cycling based on configured parameters
- Events and measurement data transmission according to condition (sabotage, movement, value over limit)
- Alive signal transmission when no other communication is made for a given period

OPERATION

Normal Mode

Several units may be connected to the CAN communication line. Each unit receives a unique identifier (UNIT_ID) within the range from 1 – 254. A separate limit value can be configured for each measured value. If the difference between a measured value and its corresponding previously sent value exceeds the limit, the unit transmits the data. The devices store configuration parameters in EEPROM so that data is not lost in the event of power loss.

Configuration commands allow the modification of:

- Output current limit value
- Output voltage values
- Interruption cycle parameters
- The input voltage range for the cathodic potentials
- Alive signal transmission time
- Automatic interruption cycle parameters

Signals from the external motion sensor and the internal sabotage sensor trigger an immediate message transmission. An integrated thermometer measures the environmental temperature for which limit values can be set with a resolution of 1°C.

To ensure that possible failures are recognized in the shortest possible time, the device can be configured to periodically send alive signals.

The device also handles an automatic interruption cycle mode. This means that at preconfigured time periods, the device switches to interruption cycle mode and measures and transmits the potentials.

Interruption Cycle Mode

The interruption cycle operation mode serves to measure the cathodic potential changes at the cathodic stations with intensive measurements. To ensure that the measurements happen simultaneously with the mobile measuring devices, the interruption cycle makes use of GPS based time synchronization.

Measurements during interruption cycling take the form illustrated in the following diagram.

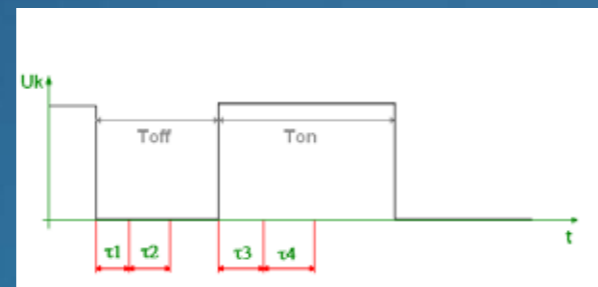

1. Based on the time synchronization, the unit turns off the cathodic voltage.
2. After t1 time, the cathodic potential measurement begins and lasts for t2 time. The measurements from the t2 period are averaged.
3. At the end of the Toff switch off period, the cathode voltage is restored.
4. After t3 time, the cathodic potential measurement begins again and lasts for t4 time. The measurements from the t4 period are then also averaged.
5. Following the Ton period, the cycle is repeated.

An M parameter can be configured for the measurements which determines the number of measurement cycles. Following an M number of interruption cycles, the averages of the measurement results are transmitted for central processing.

The data transmitted includes the voltage values of the three cathodic potential inputs in the off and on states.

Automatic Interruption Cycling Mode

To obtain a continuous picture of the effectiveness of the cathodic protection, the system was designed to be capable of a so-called automatic interruption cycling mode. This is, in effect, just one of the conditions of the normal operation mode. Essentially, at pre-configured intervals (maximum one week), the system switches to interruption cycling mode and measures the potentials. The duration of the automatic interruption cycling mode can be configured to a maximum of five hours. This function can be disabled by setting the repetition interval period to zero.

Other Information

In order to be able to connect the device to several types of cathodic stations, the input range for voltage and current received from the cathodic station can be configured. The parameters have been designated

as: U_{max}/U_{out} and I_{max}/I_{out} . The voltage transmitted to the outputs is converted to the suitable range corresponding to the configuration. For example, if the cathodic station's input range for the control voltage input is 0-3.3 V, the device's output signal can extend from 0 to 5 V. The span is 0-50 V and 0-50 A.

Communication

The CAN bus is used for communication between devices. This is an extremely reliable and fast system, which is capable of a string of 127 devices. When connected to the CAN bus, the DIWICON CB communication unit can forward the CAN packets from the cathodic station controllers to the central server. To do this it uses GSM/GPRS technology. Redundancy can be achieved by using multiple such devices. Using its own memory, the communication unit overcomes any lack of GPRS availability.

