

DIWICON-G DW 61 GEx

MAGNETIC POSITION SENSOR

This DW 61 GEx was designed to sense positions occurring in industrial applications. The position sensor is used primarily in oil, gas, and chemical industrial environments. The product has been designed to be widely applied wherever shifting or movement from a fixed position must be detected.



FEATURES

- Reed relay contact element
- High sensitivity
- Magnetic operation

OPERATION

- Normal open design
- Position signal

INDUSTRIAL DESIGN

- Certificate free Ex component
- IP67 design (IEC 529 conform)
- Lengthened cable
- Screw-in installation

TECHNICAL DATA

Power supply:	min. 3.3 VDC	
Relay type:	Reed relay	
Operational temperature:	-35°C to +60°C	
Magnet material:	Ferrite/Neodymium/AlNiCo	
Minimal magnet size:	Ferrite:	NA20x4
	Neodymium:	NA12x1.5
	AlNiCo:	NA12x1.5
Magnet positioning:	Eccentric	
Operational det. distance:	0 to 20 mm	
Recommended det. distance:	10 mm	

Threaded connector:	M32 x 1.5
Installation:	Using 2 nuts
Cable gland connector:	M16 x 1.5
Cable gland protection:	II2 GD EEx e IIC
Cable:	OZ-BL-CY 2x0.75
Cable length:	3m, 5m, 10m
Mechanical size:	NA32 x 40mm
Electrical protection:	IP67 (IEC 529 conform)
Resin casting:	Yes
Magnet:	Feritte base type NA20x4

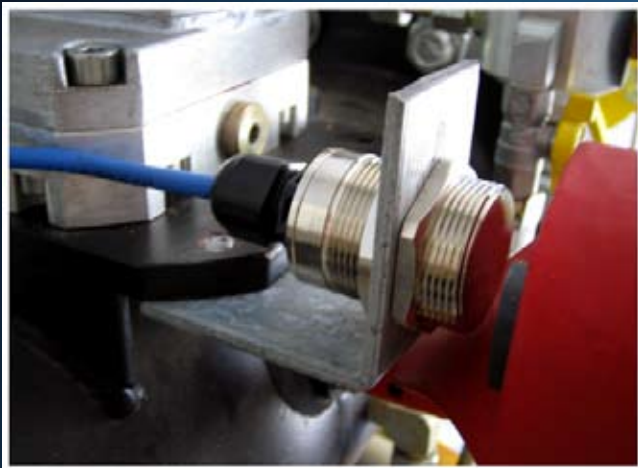

GENERAL INFORMATION

OPERATION

The switch unit within the device is a reed relay which is open in its normal state. A magnet, closely positioned to it, will create a magnetic field which closes the reed relay causing a short circuit signal within the device. If the magnet is moved, the magnetic field is lost and the reed relay is opened, thus breaking the circuit.

FUNCTIONAL DISTANCES

Correct installation is critical to proper functioning. The magnetic field and geometric extension vary depending on the properties of the magnet used. From an operational standpoint two measurements are important. The first is the distance between the magnet and the sensor, known as the detector distance. The second is the distance between the axis of the detector and the center point of the magnetic field, known as the operational eccentricity. The sensor must be positioned so that the detector distance is between 0mm and 20mm. The recommended detector distance is 10mm. The recommended operational eccentricity value is 5mm – 10mm. If there is no eccentricity, the field lines of the magnet do not close and a magnetic field is not produced.

ELECTRICAL PROTECTION

The DW 61 GEx is sealed air tight with a poured resin, thereby protecting the contact element and the cable from all types of environmental damage. The detector is categorized IP67 electrical protection according to the IEC 529.

APPLICATION

The sensor has an enhanced safety cable leader which takes into consideration the requirements of products used in explosion hazard environments. It also has intrinsic safety circuitry.

MECHANICAL INSTALLATION

The DW 61 GEx can be mounted in several ways. The detector can be screwed into the desired position with the two counter nuts included. This solution is only recommended when the detector does not need to be frequently moved or if the other end of the cable is not fixed in position. The other option is mounting it in a hole in a metal plate with the two counter nuts.

MAGNET

A magnet is necessary for the sensor to function. The minimum size of the magnet used depends on its type. The sensor will function with magnets of any material. A Ferrite magnet should be at least NA20 x 4 in size while neodymium and AlNiCo magnets should be NA2 x 1.5. Circular magnets are preferred for operation with the detector. The detector is shipped with a magnet.

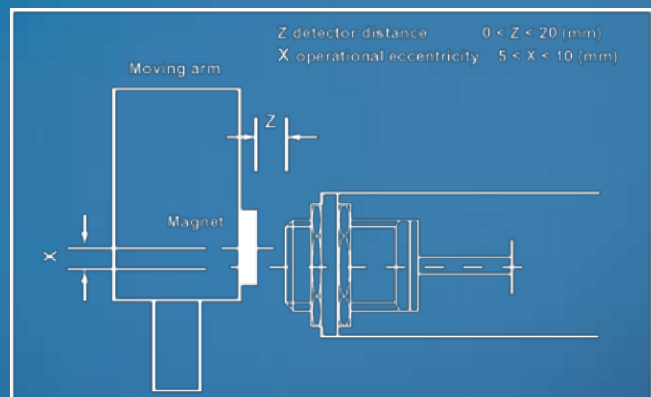

CASON

CASON Engineering Plc. Velencei út. 37. H-2030 Érd, Hungary
 Tel: +36 (23) 522-100, • Fax: +36 (23) 522-190
 office@casonplc.com • www.casonplc.com