

DIWICON-G DW 1122 GEx

EXPLOSION-PROOF MAGNETIC DETECTOR

The DW 1122 GEx magnetic detector is typically used in the oil, gas, and chemical industries on pipelines that regularly require cleaning using pipeline pigs.



OPERATION

- Creates a virtual magnetic field
- Detects fluctuations in the magnetic field
- Impulse signal output

FUNCTIONS

- Detection of pipeline pigs
- Detection of magnetic fluctuations
- Magnetic position sensing

SPECIAL FEATURES

- ATEX certification
- Dual protection

ELECTRONIC CHARACTERISTICS

- Intrinsically safe design
- 24 V DC power supply
- Minimized consumption
- High sensitivity
- Lengthened cable

INDUSTRIAL DESIGN

- ATEX certification
- Explosion-proof design
- Intrinsically safe design

TECHNICAL DATA

Nominal voltage:	+24 V DC
Voltage:	+9-35 V DC
Sensor type:	Magnetic
Output signal:	Impulse
Delay:	10-20 s
Reference voltage base:	+2.5 V
Reference voltage range:	+2.5 V \pm 0.6 V
Consumption when turned on:	16 mA
Consumption in normal mode:	6 mA

Magnetic impulse frequency:	20-50 Hz
Magnetic sensitivity:	4000 mV/G
Signal logical 0:	0 mA
Signal logical 1:	10 mA
Stabilizer output voltage:	+5 V DC
Environmental temperature:	-35°C to +60°C
Storage temperature:	-40°C to +85°C
Maximum humidity:	98% RH
IP protection:	67
Ex protection:	II1 G EEx d ia T6

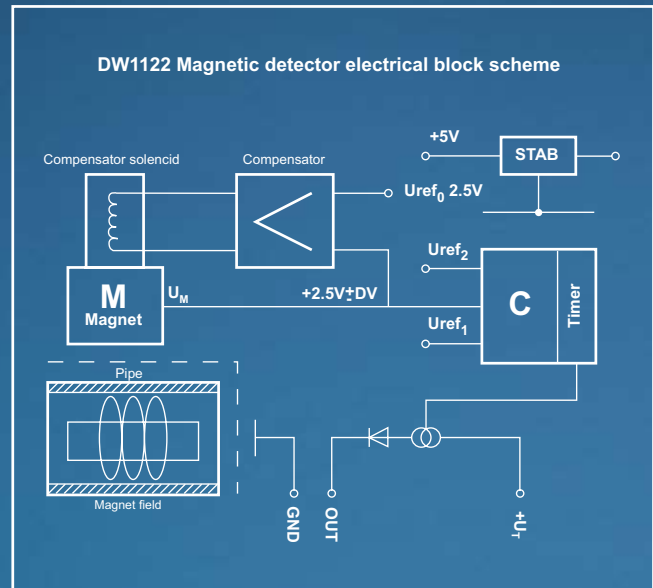
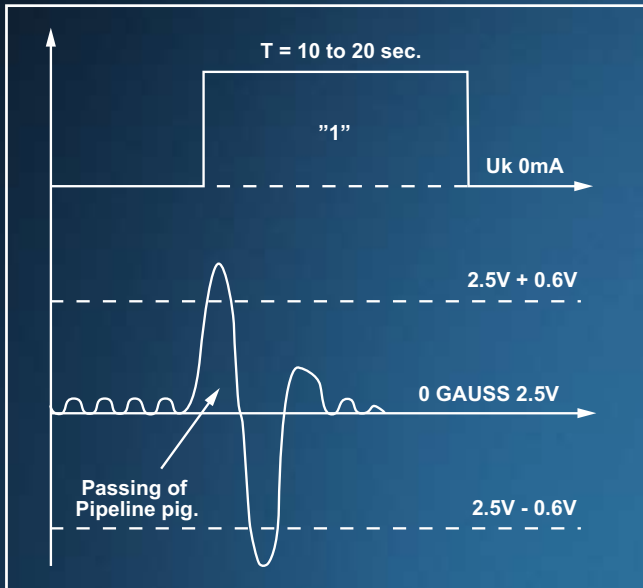

GENERAL INFORMATION

GENERAL CHARACTERISTICS

The magnetic detector is intrinsically safe, explosion-proof, highly sensitive, and consumes minimal power. It has also received ATEX certification.

OPERATION

The magnetic detector senses magnetic field lines as they pass perpendicularly to it. It is mounted on the pipeline so that there is less than 5 mm between the detector and the pipe. The compensation amplifier and the compensation coil build equally strong fields of opposite direction to outside fields that effectively quench each other. Thus, the measurement practically takes place in a virtual 0 magnetic field. Part of the electronics is a window comparator and a monostable timer that performs time delay tasks. The window comparator is designed so that it sends a logical 1 signal if the 2.5 V value belonging to the 0 GAUSS is exceeded by more than \pm 0.6 V. The TIMER maintains the logical 1 signal for 10 to 20 seconds.

ELECTRONICS, POWER SUPPLY

The central unit of the sensing and regulating electronics includes a magnetic field distortion sensor and handles the processing of the sensor signals. It also includes a regulating circuit to compensate for static magnetic fields. To increase the power consumption efficiency, a switch operated power supply provides power. Because of this feature, the device can function reliably behind a Zener barrier. The magnetic detector operates with a 24 V DC nominal power supply.

SWITCHING ON, WAKING UP

The wake-up period of the device after being switched on is about 3 minutes. Within this period, the system calibrates to the GAUSS 0 +2.5 V level. During this time, the output provides a logical 1 signal. When the system is live, the output signal changes to logical 0. This start-up procedure is also carried out after a cut in power. If the logical 0 signal does not occur after 3 minutes, either the system has encountered an error or the magnetic perturbation of the pipeline is at such a level that the device is not able to compensate. If this happens, it is recommended to install the device at a different point on the pipeline. Continuous attention to the power consumption can help filter out parasite magnetic disturbances since these can raise the consumption to 10mA in contrast to the normal consumption of 6mA.

OPERATION BEHIND A ZENER BARRIER

The use of an intrinsically safe Pepperl & Fuchs Z787.H type Zener barrier with EEx ia IIC T6 protection is recommended. The Zener barrier should be positioned outside of the Ex zone. The output cables must be connected to the local junction box. The Zener barrier, the magnetic detector, and the pipeline must be connected with a potential compensating cable. The potential compensating cable should not be longer than 100 m with a resistance of less than 1 Ohm. The cross section of this cable should be greater than 4 mm².

CASON

CASON Engineering Plc. Velencei út 37. H-2030 Érd, Hungary

T: +36 (23) 522-100 • F: +36 (23) 522-190

office@casonplc.com • www.casonplc.com